

E1 AND E2 BRAIN BOARDS

Features

- > Drop-in replacement for existing B1 and B2 brain boards on an Optomux serial network
- > Dual network connectivity: RS-422/485 serial and 10/100 Mbps Ethernet
- > Optomux, Modbus/TCP, and OptoMMP protocol support
- > Can use Opto 22 PAC Project software for control, HMI, and OPC server

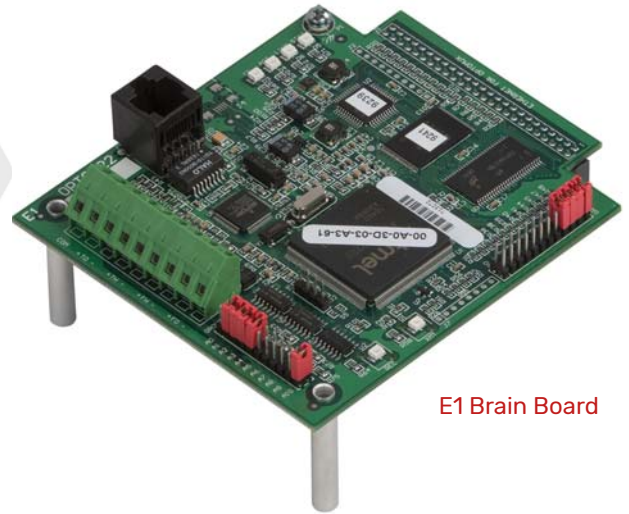

E1 Brain Board

DESCRIPTION

E1 and E2 brain boards are Ethernet-ready I/O and communication processors for digital and analog I/O systems. The E1 connects to a rack of Opto 22 G1, G4, or Quad Pak™ digital I/O modules, while the E2 connects to a rack of Opto 22 G1 analog I/O modules. Each brain board communicates with a host computer and performs control functions for each I/O point.

Designed as drop-in replacements for Opto 22's serial-based B1 and B2 brain boards, E1 and E2 brain boards connect to standard 10/100 Mbps Ethernet networks while including support for serial Optomux®-based networks.

Communication and Protocol Support

Ethernet support makes E1 and E2 brain boards ideal for upgrading existing Optomux I/O systems to use Ethernet networking while preserving existing I/O racks, modules, and field wiring. Using RS-422/485 serial networks, E1 and E2 brain boards provide Optomux-based capabilities identical to B1 and B2 brain boards.

When Ethernet networks are used, E1 and E2 I/O units also support Modbus®/TCP clients, custom Optomux applications migrated to Ethernet, custom software applications written using Opto 22's memory-mapped OptoMMP™ communication protocol, and applications using Opto 22's PAC Project™ software. PAC Project Basic includes PAC Control™ for flowchart-based programming and PAC Display™ for HMI. PAC Project Professional adds OptoOPCServer™ for data connectivity with OLE for Process Control (OPC) 2.0-compliant clients and OptoDataLink™ for exchanging data with commonly used databases, such as MySQL® and Microsoft® SQL Server®.

Because the E1 and E2 can use these Ethernet-based protocols simultaneously while still communicating with an existing Optomux software application via a serial network, E1 and E2 brain boards greatly expand your options for controlling and monitoring your I/O system.

Programming and Configuration

There are several options for controlling, monitoring, and acquiring data from E1 and E2 brain boards.

Optomux over serial or Ethernet networks

Use your existing serial-based Optomux host application.

Here, one E1 or E2 brain board routes Optomux commands from a serial connection to other brain boards connected to an Ethernet network. This approach is illustrated in the system diagram on [page 6](#).

Migrate your existing serial-based Optomux host application to Ethernet. The Optomux for Ethernet software toolkit is shipped with E1 and E2 brain boards and can also be downloaded free of charge from the Opto 22 website.

Communication settings for connecting to an Optomux serial network are made using on-board jumpers.

Ethernet-based communication options

Use an Ethernet-based Opto 22 industrial controller that runs a PAC Control *strategy* (or control program) and communicates with all Opto 22 devices on the Ethernet network. This approach also makes it possible to use the PAC Project software applications PAC Display for HMI, OptoOPCServer for OPC connectivity, and OptoDataLink for

Part Numbers

Part	Description
E1	16-Channel Digital Optomux Protocol Brain Board for Serial and Ethernet Networks
E2	16-Channel Analog Optomux Protocol Brain Board for Serial and Ethernet Networks



database communication. See [page 7](#) for an illustration of an I/O system controlled and monitored by PAC Project software.

Use a custom or third-party Modbus/TCP-based client application. This option is illustrated on [page 8](#).

Create a custom software application based on OptoMMP, Opto 22's IEEE 1394-based memory-mapped protocol.

Ethernet network, I/O point, and other E1 and E2 configuration settings are made using Opto 22's PAC Manager configuration software. This software is included on the CD shipped with E1s and E2s, and is also available as a free download from the Opto 22 website.

Optomux Compatibility

E1 and E2 brain boards are designed as drop-in replacements for Opto 22 B1 and B2 brain boards. E1 and E2 boards duplicate digital (B1) and analog (B2) I/O functions, respectively, and provide identical Optomux-based capabilities. See "[Optomux Protocol Brain Comparison](#)" on [page 3](#) for a detailed comparison of capabilities for Optomux brains and brain boards.

Compatible Opto 22 I/O Racks

I/O Module	E1 (Digital)	E2 (Analog)
G4 Digital	G4PB8H, G4PB16H, G4PB16HC	n/a
Quad Pak	PB16HQ	n/a
Standard (G1)	PB4H, PB8H, PB16H, PB16HC	PB4AH, PB8AH, PB16AH
Integral I/O Racks	PB16J/K/L, G4PB16J/K/L	n/a

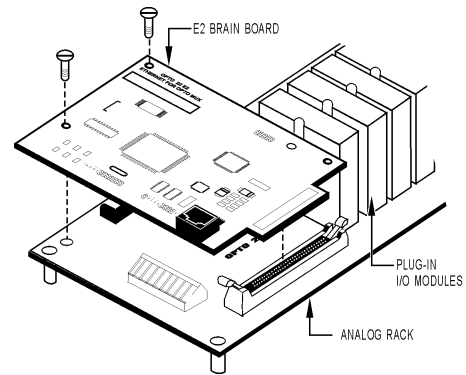
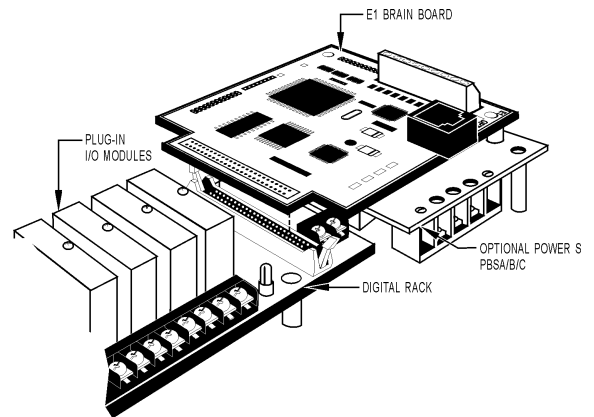

E1 and E2 brain boards plug into Opto 22 digital and analog I/O racks.



Optomux Protocol Brain Comparison

The following table compares Opto 22's Optomux-capable brain boards: B1, E1, B2, and E2. Features shown are for the Optomux protocol. Features will be different if the brain is used with another protocol. See the brain's data sheet for specifications.

Feature	B1	E1	B2	E2
Optomux Digital Features				
Read/write to point	●	●		
Input latching	●	●		
Counting	●	●		
Pulse duration measurement	●	●		
Pulse generation	●	●		
Time delays (10 ms resolution)	●	●		
Watchdog timer	●	●		
Optomux Analog Features				
Read/write to point in Engineering units			●	●
Input averaging			●	●
Minimum/maximum values (peak/valley recording)			●	●
Out of range testing (high/low)			●	●
Offset and gain calculation			●	●
Waveform generation			●	●
Watchdog timer			●	●
Networks				
Serial (RS-422/485)	●	●	●	●
Ethernet		●		●
Module families				
G1 analog modules			●	●
G1 digital modules	●	●		
G4 digital modules	●	●		
Quad Pak digital modules	●	●		
Integral digital I/O racks	●	●		
Additional Protocols Supported				
Modbus/TCP		●		●
OptoMMP		●		●

E1 Features and Protocols

The following table shows features available on an E1 digital I/O unit depending on the protocol used.

Feature	Optomux	OptoMMP ¹	Modbus/TCP
Read/write to point	●	●	●
Input latches	● ²	● ³	● ³
Counters ⁴	●	●	●
Pulse duration measurement	●		
Pulse generation	●		
Time delays (10 ms resolution)	●		
Watchdog timer	●	●	●
Networks			
Serial (RS-422/485)	●		
Ethernet	●	●	●

1 This protocol is also used with all PAC Project applications.

2 One latch per point is available; it can be configured as on-to-off or off-to-on.

3 Two latches per point are always available; no configuration is needed.

4 Maximum counter frequency is 400 Hz. Counters roll over at 65,535.

E2 Features and Protocols

The following table shows features available on an E2 I/O analog unit depending on the protocol used.

Feature	Optomux	OptoMMP ¹	Modbus/TCP
Read/write to point in Engineering units		●	●
Read/write to point in counts	●	●	
Input averaging	●		
Minimum/maximum values (peak/valley recording) ²	●	●	●
High/low range testing	●		
Offset and gain calculation	●	●	●
Waveform generation	●		
Watchdog timer	●	●	
Networks			
Serial (RS-422/485)	●		
Ethernet	●	●	●

1 This protocol is also used with all PAC Project applications.

2 If an ICTD or thermocouple module is used, minimum and maximum values are returned as counts.



SYSTEM ARCHITECTURE

Optomux-based Control Using an Ethernet Network

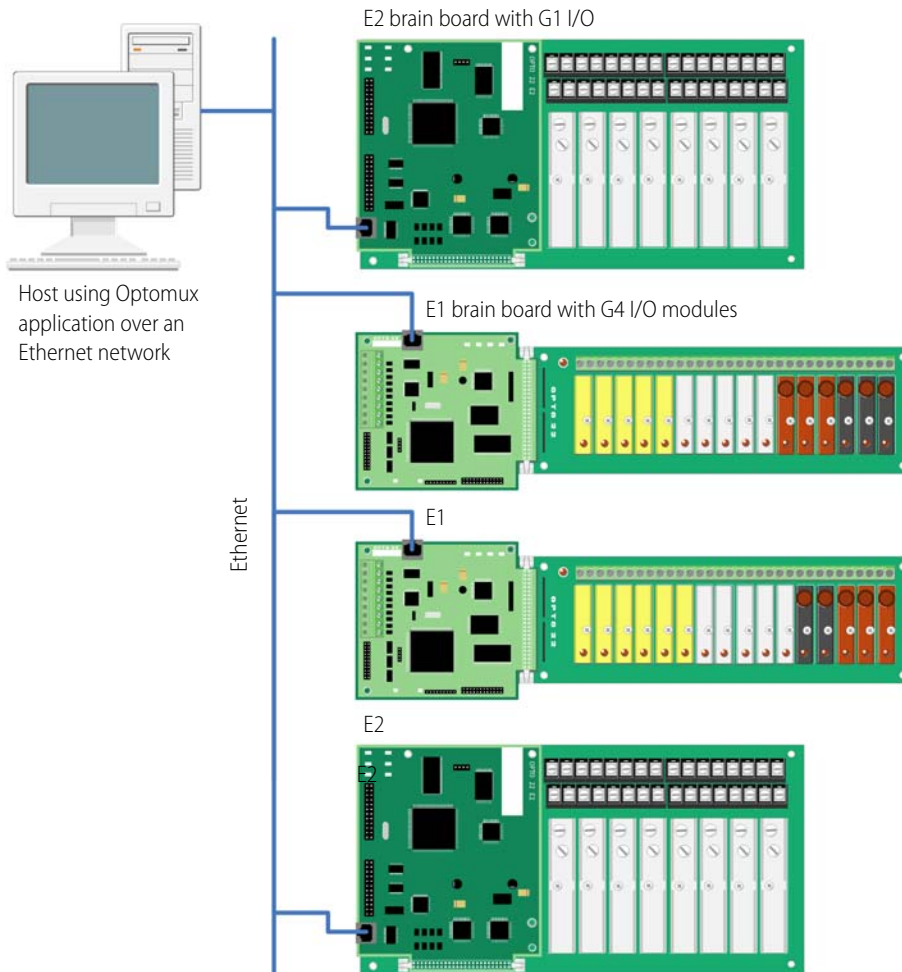

This diagram shows an Optomux-based I/O system connected over an Ethernet network. In this system, each original B1 or B2 brain board has been replaced with an **E1** or **E2**, and all brain boards are connected to an Ethernet network.

The PC is running an Optomux host application written using the Optomux Protocol Driver. Using this driver, legacy Optomux applications for serial networks can be converted to use Ethernet networks. The Optomux Protocol Driver and documentation are included with E1 and E2 brain boards, and can also be downloaded free of charge from the Opto 22 website.

For more information on using E1 and E2 brain boards, see the *E1 and E2 User's Guide* (form 1563). Programming information for the Optomux Protocol Driver is in the *Optomux Protocol Guide* (form 1572).



Routing Serial Optomux-based Control over an Ethernet Network

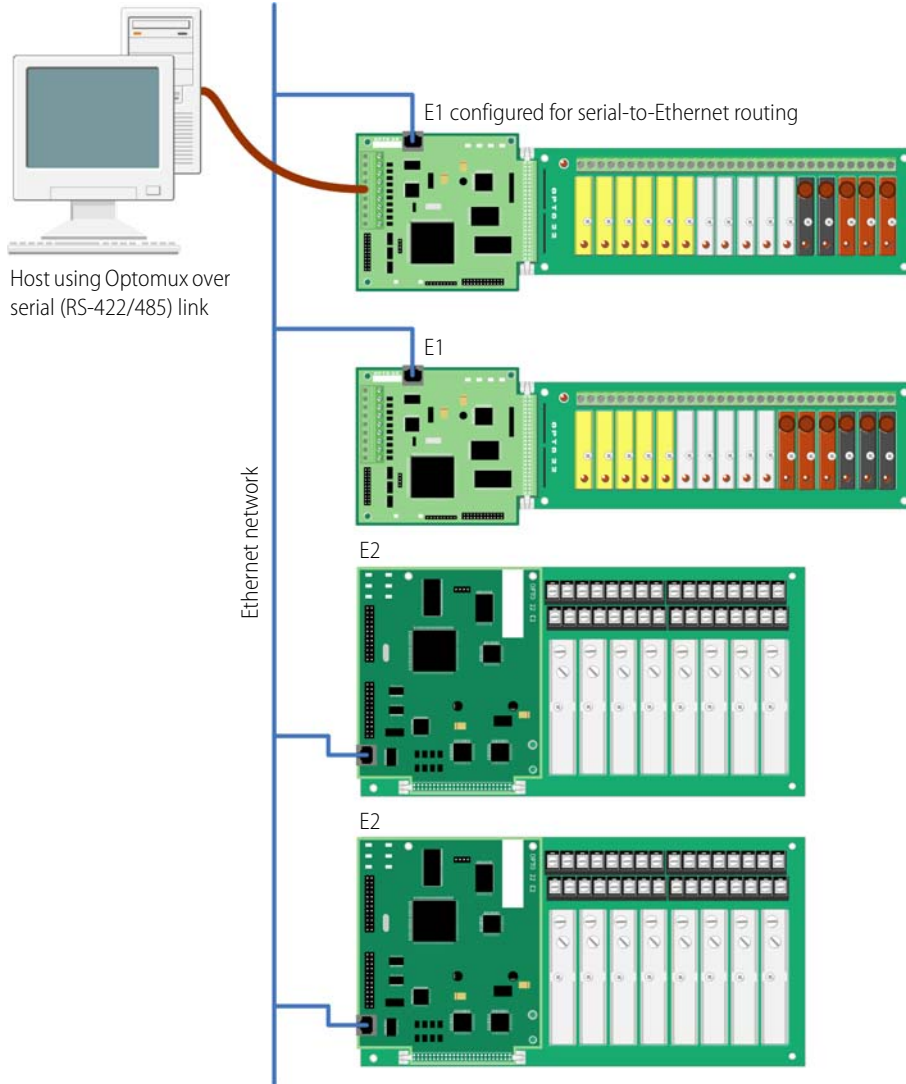

This diagram shows how an existing Optomux-based I/O system for an RS-422/485 serial network can be migrated to an Ethernet network. In this system, each original B1 or B2 brain board has been replaced with an **E1** or **E2**, and all brain boards are connected to an Ethernet network.

One E1 or E2 brain board is connected via an RS-422/485 serial connection to the host PC running the Optomux application. For each Optomux command sent from the PC, this brain board determines which I/O unit the command must be sent to and then routes the command to that unit over the Ethernet network. I/O point data is routed from the E1 and E2 brain boards to the PC in a similar manner.

Because an Ethernet network is used, the existing Optomux application can now monitor and control E1 and E2 I/O units located far beyond the reach of the original RS-422/485 serial network—for example, in a different building, or even on another continent.

For more information on using E1 and E2 brain boards in an existing Optomux I/O system, see the *E1 and E2 Architecture and Migration Overview* (form 1567) and the *E1 and E2 User's Guide* (form 1563).



Integrating E1- or E2-based I/O into a PAC Project™-based System

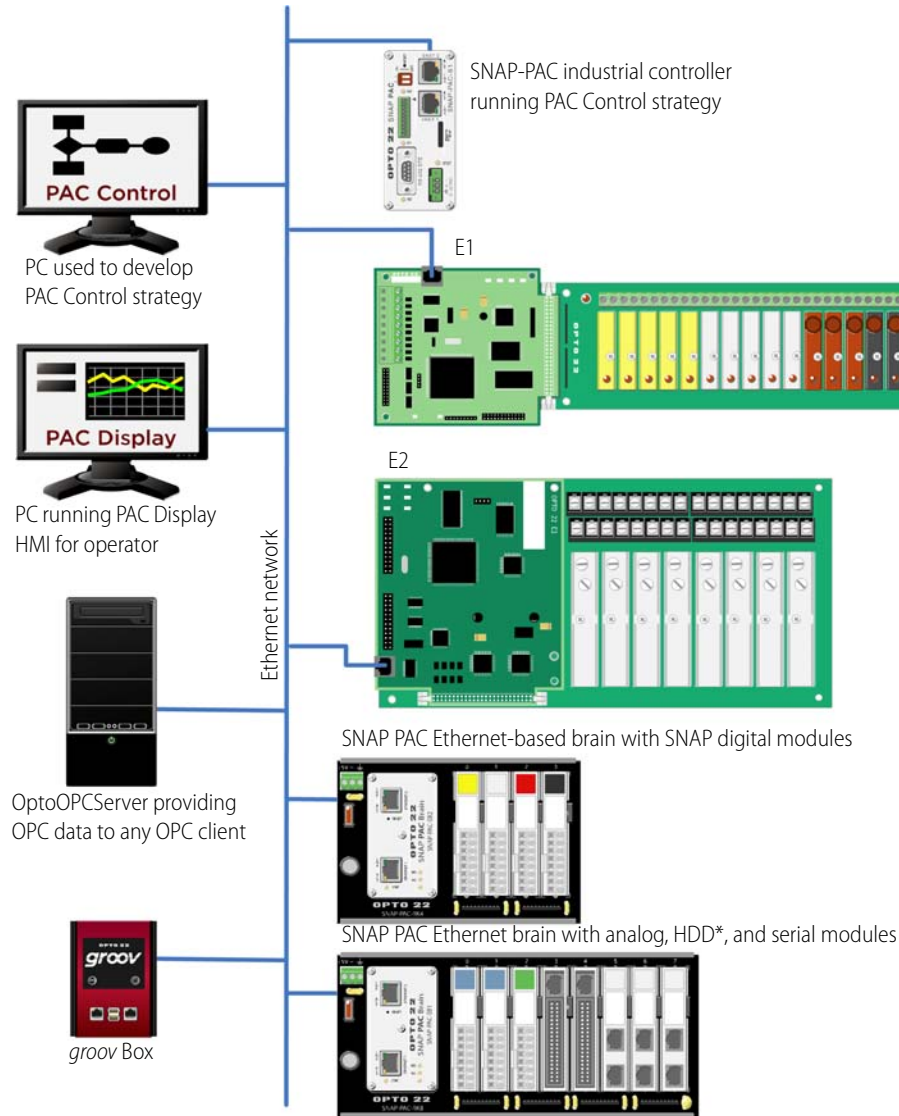

This diagram shows **E1** and **E2** I/O units integrated into a modern Opto 22 SNAP PAC System, with all devices connected over an Ethernet network.

In this system, a **SNAP-PAC-S1** industrial controller running a PAC Control control program, or *strategy*, communicates with the E1 and E2 I/O units, as well as with two SNAP I/O units that have SNAP PAC Ethernet brains. The controller is programmed using **PAC Control** software for Microsoft Windows®. PAC Control software is included with Opto 22 SNAP PAC controllers and can also be downloaded free of charge from the Opto 22 website.

As the controller strategy is executed, an operator interface runs on a PC to monitor and control the entire I/O system. This *human-machine interface* (HMI) is created using **PAC Display** HMI software.

Running on a separate PC, **OptoOPCServer** software can provide I/O point data and other information from the controller, brain boards, and brains to any OPC 2.0-compliant application.

A **groov Box™** is also on the network, providing a simple way to build and view mobile operator interfaces for the system, so your authorized users can monitor or control equipment as needed from anywhere, using an off-the-shelf smartphone or tablet.

*SNAP high-density digital (HDD) modules provide 32 points per module.



Modbus/TCP-based Control Using E1 and E2 I/O Units

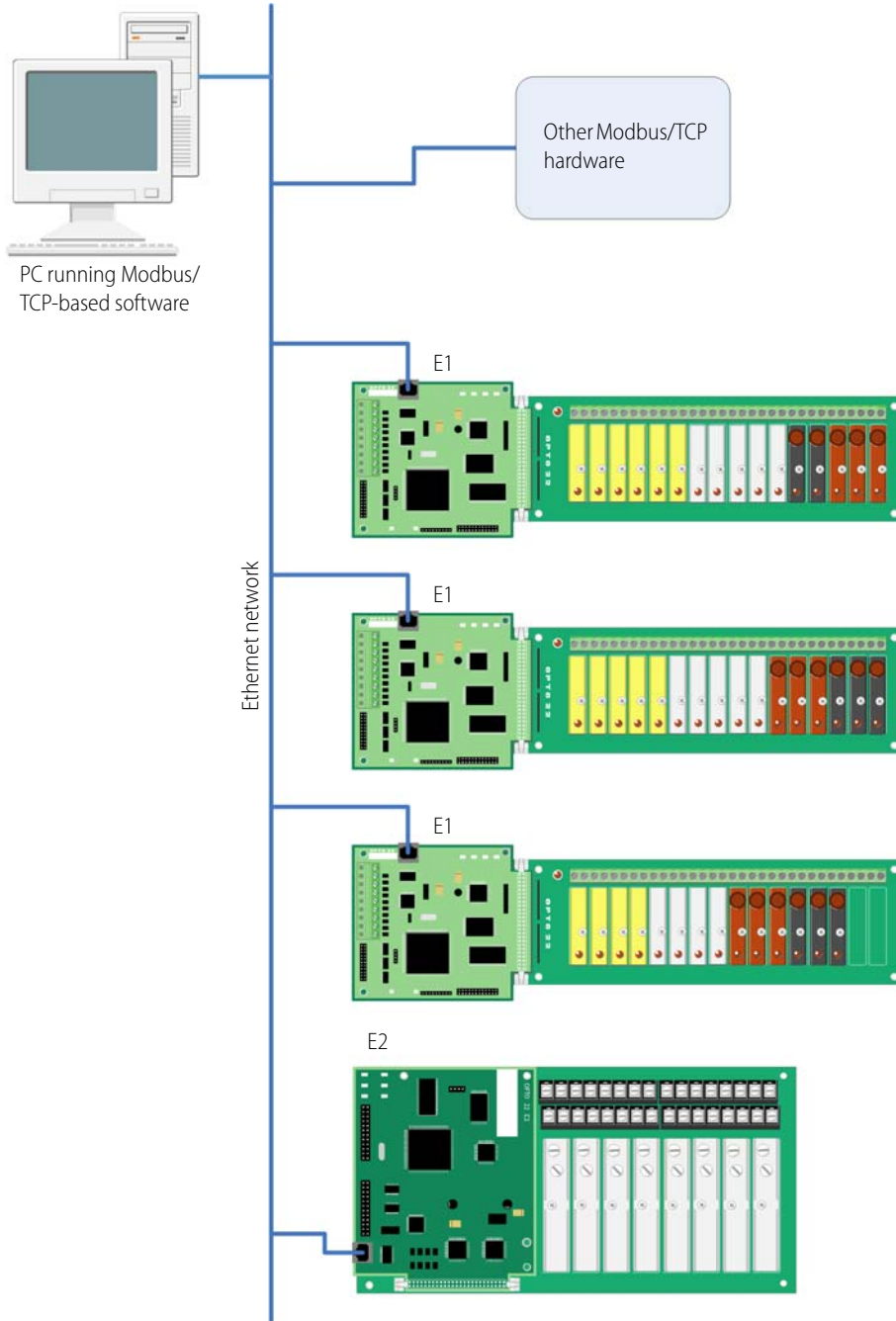

This diagram shows an **E1**- and **E2**-based I/O system controlled by Modbus/TCP software.

In this system, each original B1 or B2 brain board has been replaced with an E1 or E2, and all brain boards are connected to an Ethernet network.

Modbus/TCP software running on a PC communicates with the E1s and E2s over the Ethernet network to control and monitor I/O points.

Also connected to the Ethernet network is a Modbus/TCP hardware device that is monitoring I/O point information independent of the primary control system.

Technical Specifications

Power Requirements	5.0–5.2 VDC @ 0.5 amps (excludes digital and analog module power requirements) *
Ethernet Network Interface: Type Connector Rate Supported Protocols Maximum Segment Length	IEEE 802.3 network, 10Base-T/100Base-TX RJ-45 10/100 Mbps, half or full duplex Optomux over Ethernet, Modbus/TCP, OptoMMP (Opto 22's IEEE 1394-based memory-mapped protocol) 100 m (328 ft.) with Category 5 or superior UTP
Serial Network Interface: Type Connector Data Rates Supported Protocols Network Range	RS-422/485 serial link E1: Terminal block; E2: Terminal block (on mounting rack) 300, 600, 1200, 2400, 4800, 9600, 19200, and 38400 baud Optomux Up to 32 Optomux stations configured for multidrop can be used on a serial network of up to 1524 m (5000 ft.) total length. Up to 256 Optomux stations and longer line lengths can be used by installing network repeaters. Up to 256 Optomux stations configured for repeat mode can exist on a network.
Optomux I/O Functions	Digital I/O (E1): Read Point, Write Point, Latch Point (On/Off), Count, Pulse Duration, Time Delay, Pulse Generation, Watchdog Timer Analog I/O (E2): Read Point, Write Point, Input Averaging, Min/Max Recording (peak and valley), High/Low Range Testing, Offset and Gain Calculation, Waveform Generation, Watchdog Timer
Modbus/TCP, OptoMMP, and OPC I/O Functions	With these protocols, the following brain-based features are not available: No pulsing or time delay (E1) No pulse measurement No input averaging or waveform generation (E2)
LED Indicators	Status, Link, Activity, Full duplex, Transmit (serial), Receive (serial)
Jumper-selectable Serial Options	Group A: Multidrop or repeat mode, RS-485 termination and biasing Group B: Serial address (0 to 255), baud rate, 2- or 4-pass protocol
Operating Temperature	0 °C to 70 °C
Storage Temperature	–40 °C to 85 °C
Humidity	0–95% humidity, non-condensing
Agency Approvals	DFARS
Warranty	30 months

* ±15 VDC ±0.25 V is required for the analog modules. Current depends on the number and types of modules installed. A 24 VDC power supply is required for analog modules that need a current loop source.

DIMENSIONAL DRAWINGS

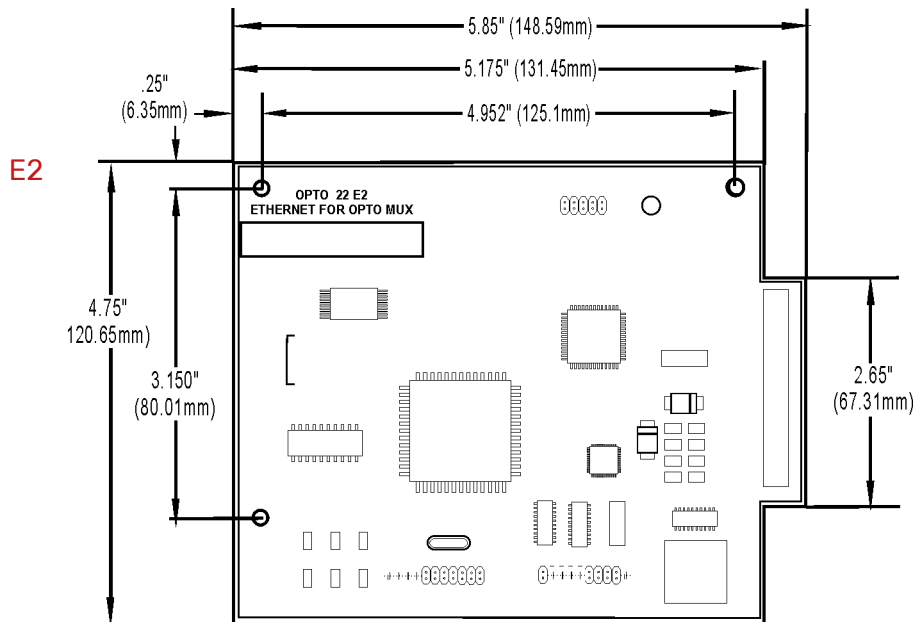
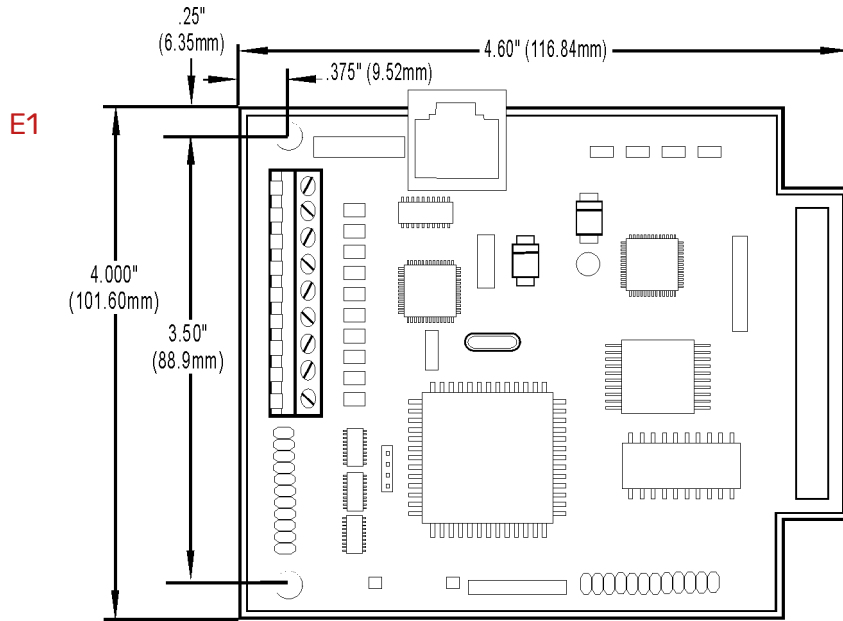

PRODUCTS

Opto 22 develops and manufactures reliable, easy-to-use, open standards-based hardware and software products used worldwide.

Industrial automation, process control, building automation, industrial refrigeration, remote monitoring, data acquisition, and Industrial Internet of Things (IIoT) applications all rely on Opto 22.



groov

Monitor and control your equipment from anywhere using your smartphone or tablet with groov. Build your own mobile app easily—just drag, drop, and tag. No programming or coding. Visit groov.com for more information and your free trial.

SNAP PAC System

Developer- and IIoT-ready, the SNAP PAC System connects physical assets to databases and applications using open standards. The SNAP PAC System consists of four integrated components:

- SNAP PAC controllers
- PAC Project™ Software Suite
- SNAP PAC brains
- SNAP I/O™

SNAP PAC Controllers

SNAP PAC programmable automation controllers handle a wide range of digital, analog, and serial functions for data collection, remote monitoring, process control, and discrete and hybrid manufacturing.

For IIoT applications and easier integration with company systems, standalone and rack-mounted SNAP PACs include a built-in HTTP/HTTPS server and **RESTful API** (application program interface). The REST API gives you secure, direct access to I/O and variable data using your choice of programming languages. No middleware, protocol converters, drivers, or gateways needed.

Based on open Ethernet and Internet Protocol (IP) standards, SNAP PACs make it easier to build or extend a system without the expense and limitations of proprietary networks and protocols.

PAC Project Software Suite

Opto 22's PAC Project Software Suite offers full-featured, cost-effective control programming, HMI (human machine interface), OPC server, and database connectivity software.

Control programming includes both easy-to-learn flowcharts and optional scripting. Commands are in plain English; variables and I/O point names are fully descriptive.

PAC Project Basic offers control and HMI tools and is free for download on our website, PAC Project Professional, available for separate purchase, adds one SoftPAC software-based controller, OptoOPCServer, OptoDataLink, options for controller redundancy or segmented networking, and support for legacy Opto 22 serial *mistic*™ I/O units.

SNAP PAC Brains

While SNAP PAC controllers provide central control and data distribution, SNAP PAC brains provide distributed intelligence for I/O processing and communications. Brains offer analog, digital, and serial functions, including thermocouple linearization, local PID loop control, watchdog, totalizing, and much more.

SNAP I/O

I/O provides the local connection to sensors and equipment. Opto 22 SNAP I/O offers 1 to 32 points of reliable I/O per module. Analog, digital, and serial modules are mixed on one mounting rack and controlled by a SNAP PAC brain or rack-mounted PAC.

QUALITY

Founded in 1974, Opto 22 has established a worldwide reputation for high-quality products. All are made in the U.S.A. at our manufacturing facility in Temecula, California.



Because we test each product twice before it leaves our factory, rather than only testing a sample of each batch, we can guarantee most solid-state relays and optically isolated I/O modules for life.

